

NOTE: [ELIMINARE BAVE E SPIGOLI VIVI]

LE TOLLERANZE SI INTENDONO A TRATTAMENTO TERMICO/SUPERFICIALE FINITO

MATERIAL:	WEIGHT:	EG:	SCALE:	1:5	GENERAL TOLERANCE: UNI-EN ISO 2768 mK
SURFACE FINISH:	CREATION DATE:	05/10/2020	SIZE:	A1	NON-QUOTED CHARACTERS: 0.5x45°
DESCRIPTION:	SHEET:	1/1	CODE:	PM.101	UNQUOTED RAYS: 0.4 mm



THE PRESENT DOCUMENT IS EXCLUSIVE PROPERTY OF V-SHAPES SRL.  
AS LEGAL CONDITION IS FORBIDDEN COPY OR COMMUNICATION  
TO THIRD PARTY WITHOUT AUTHORIZATION BY V-SHAPES SRL.



**PRIME MACHINE FORMAT CHANGE (execution time 20 min):**

- position rollers for the required format (see fig.1)
- replace the rotary cutting blade axis (see fig.2)
- pre-cutting blade replacements (if necessary)

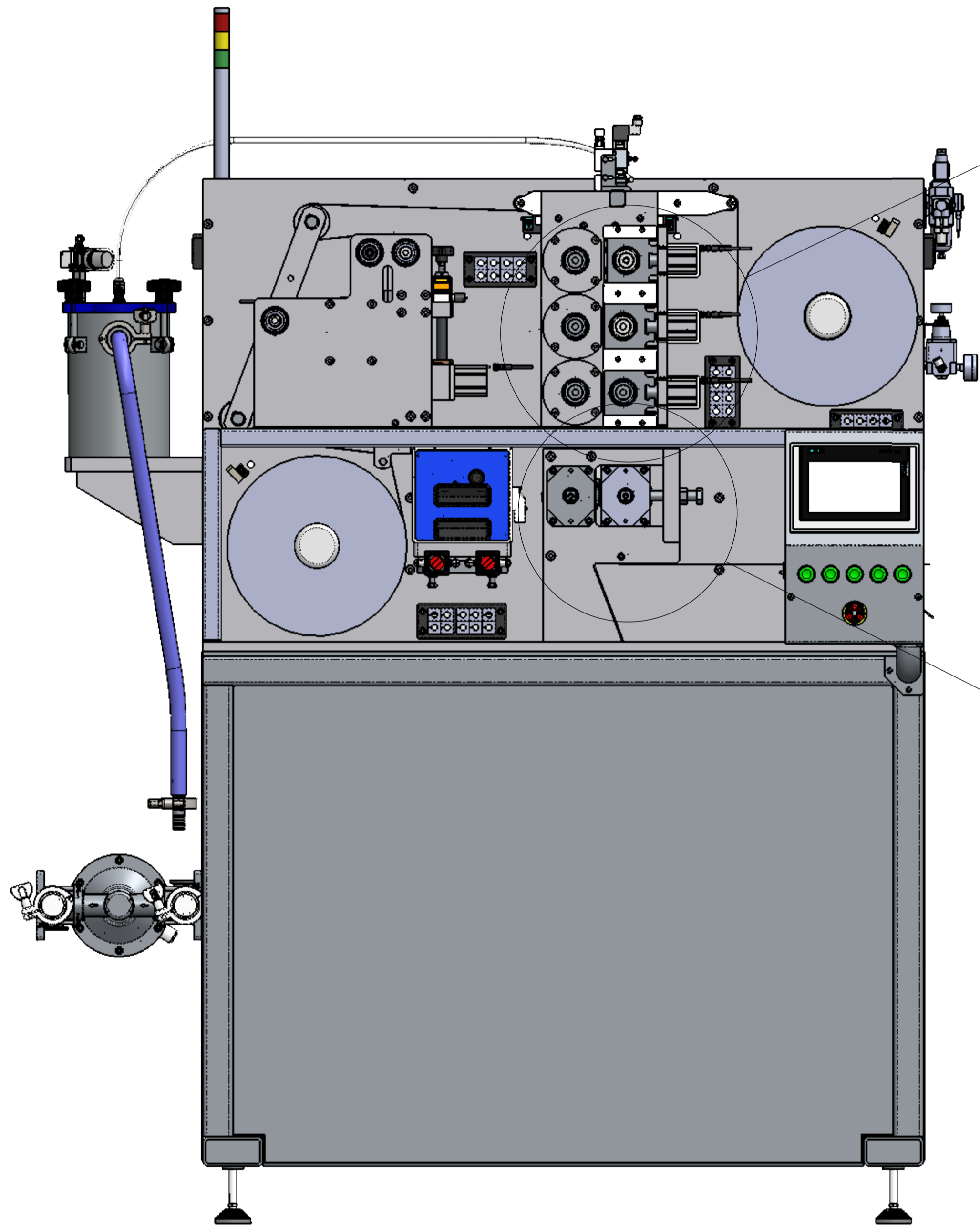

fig.1

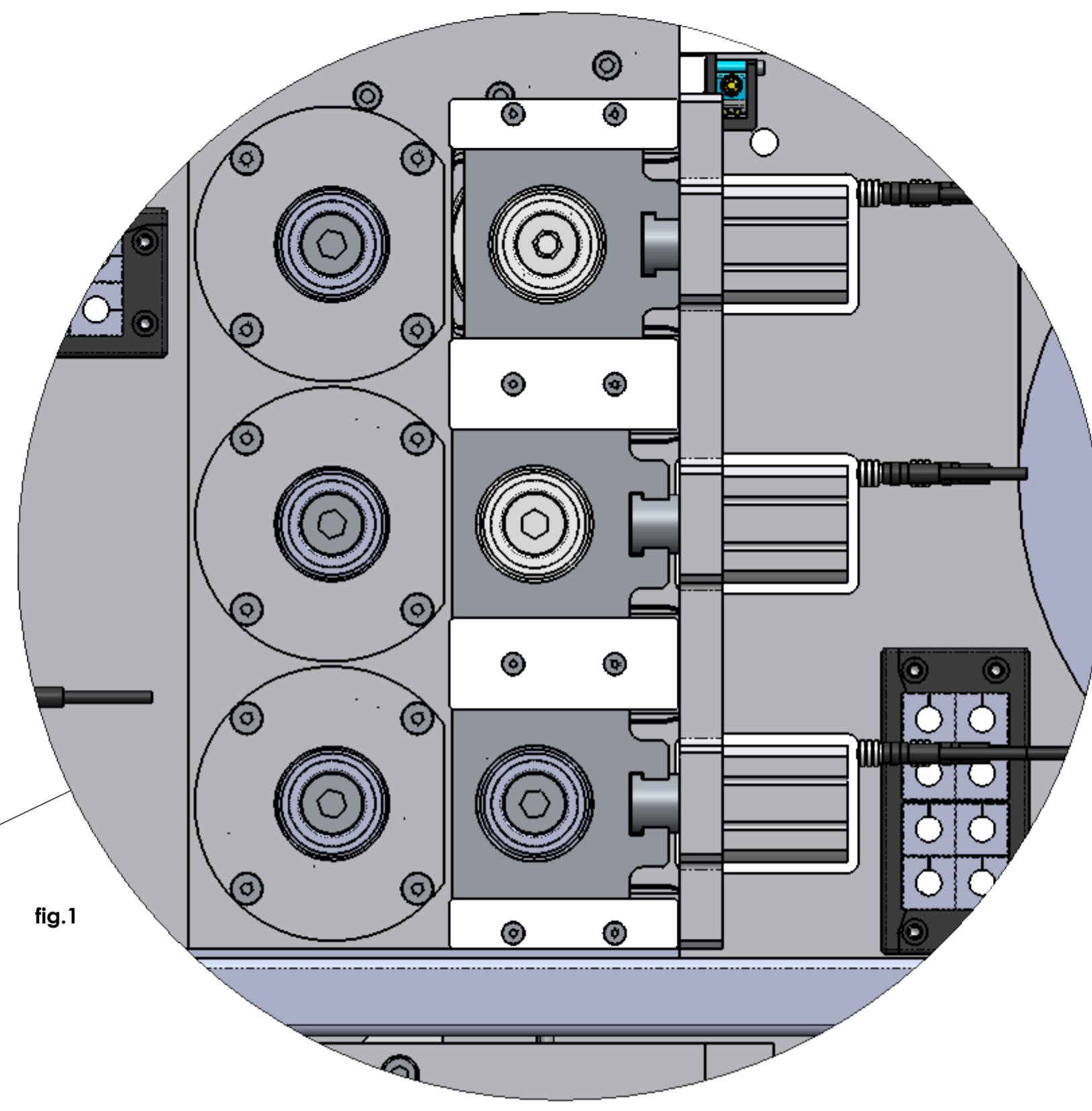
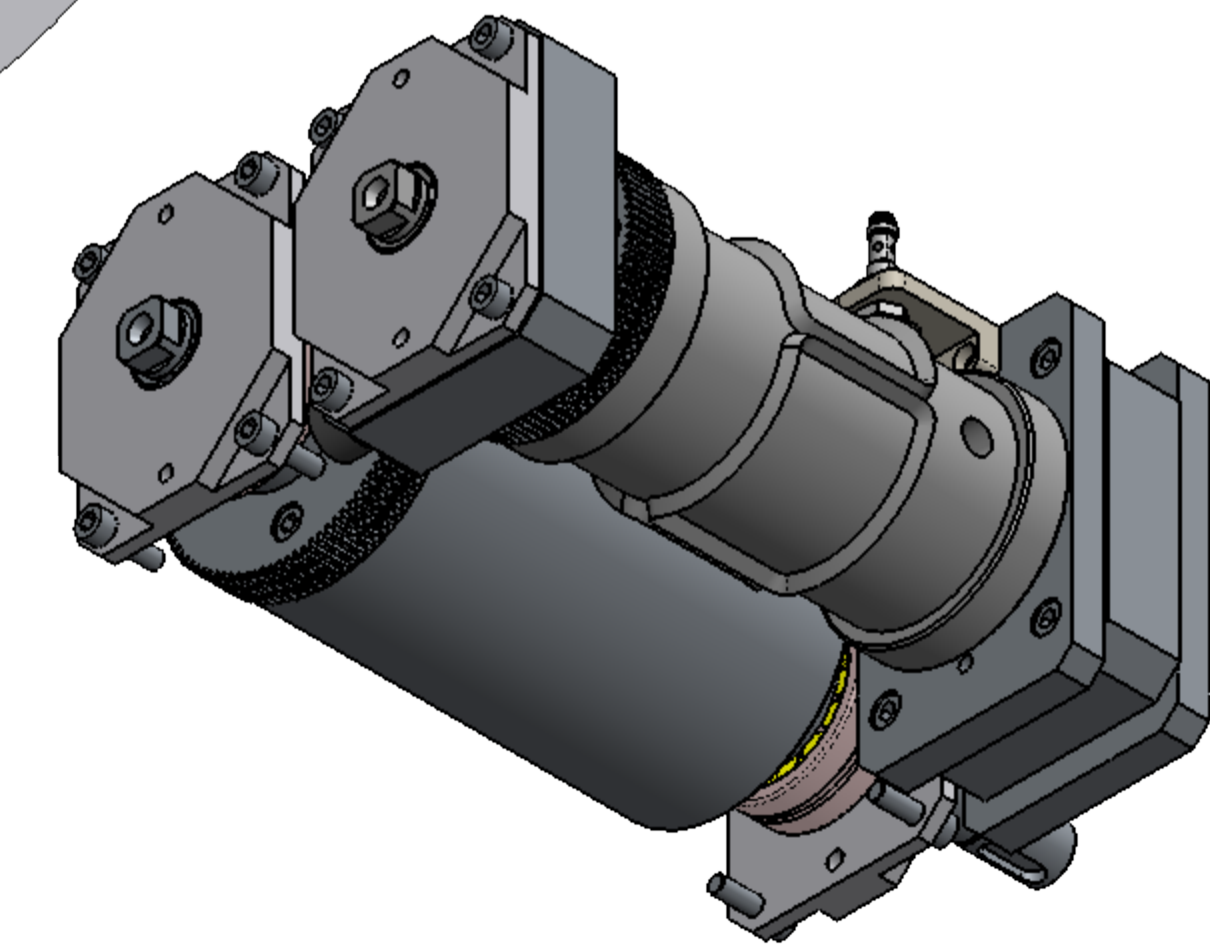
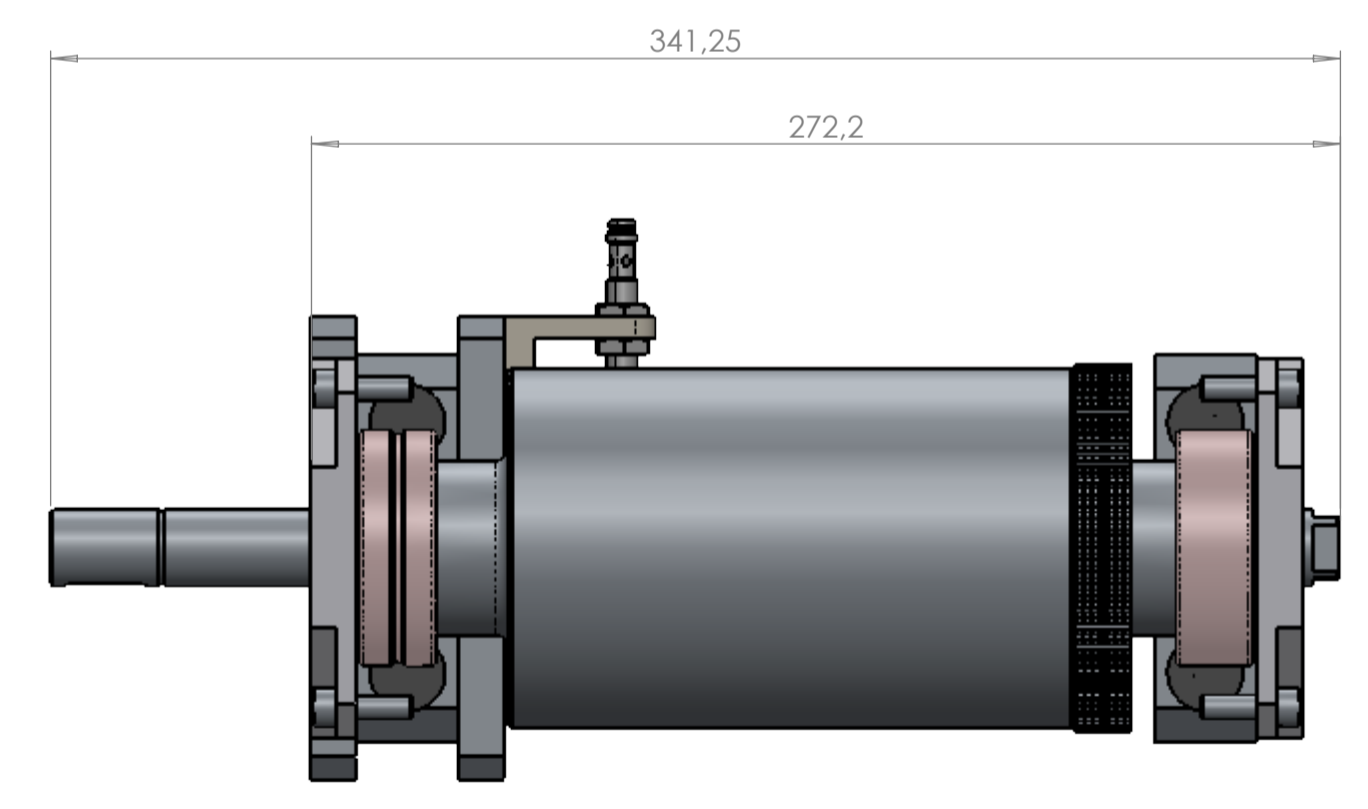
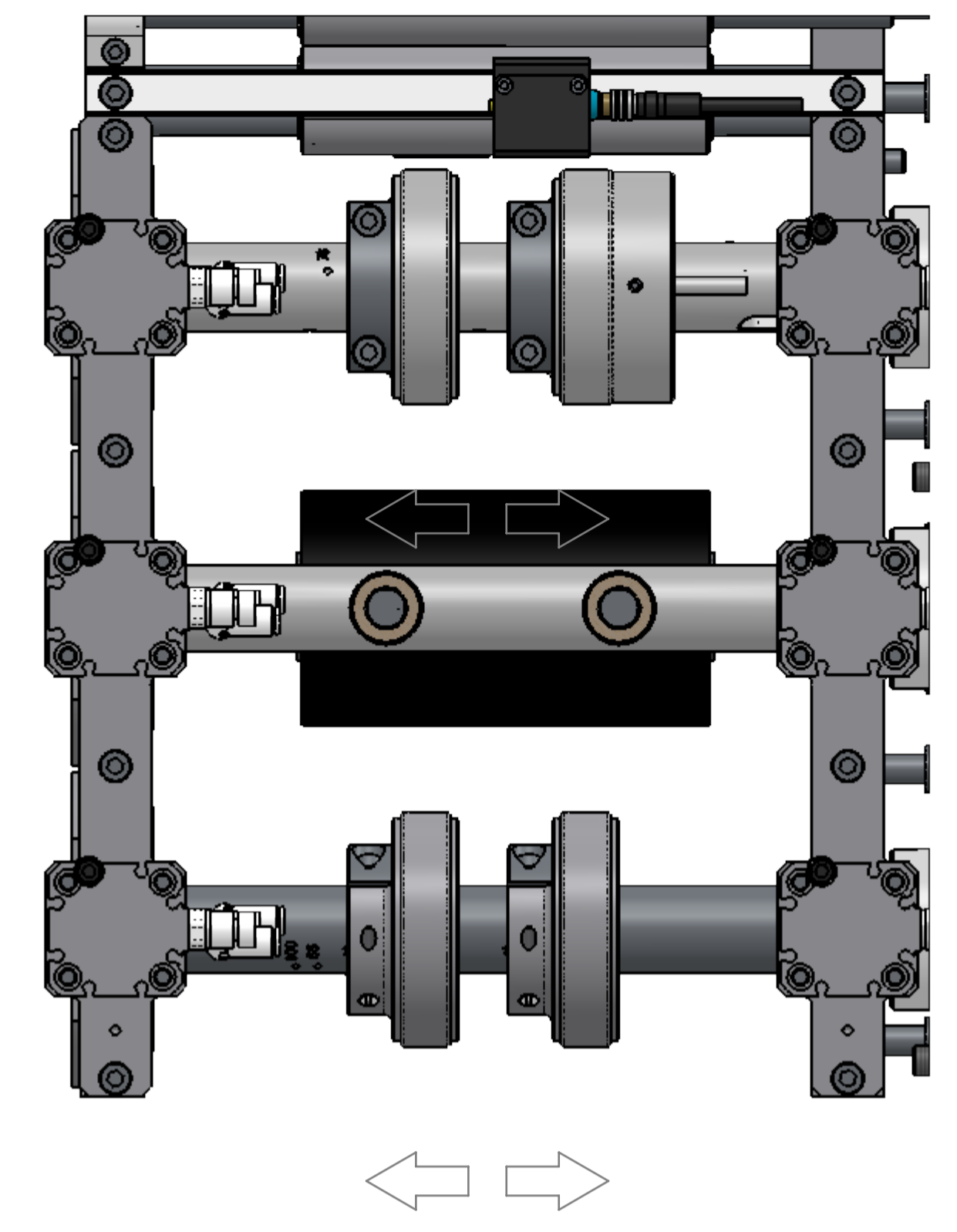
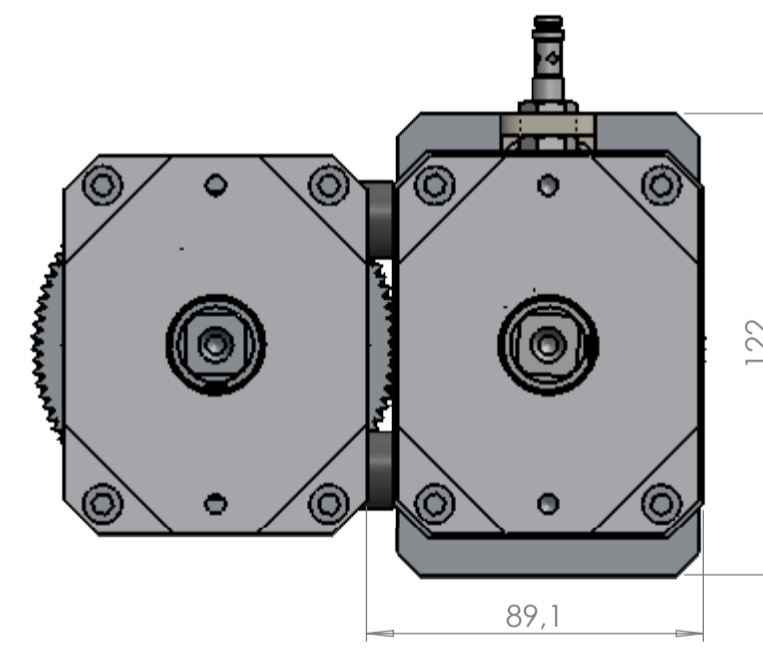
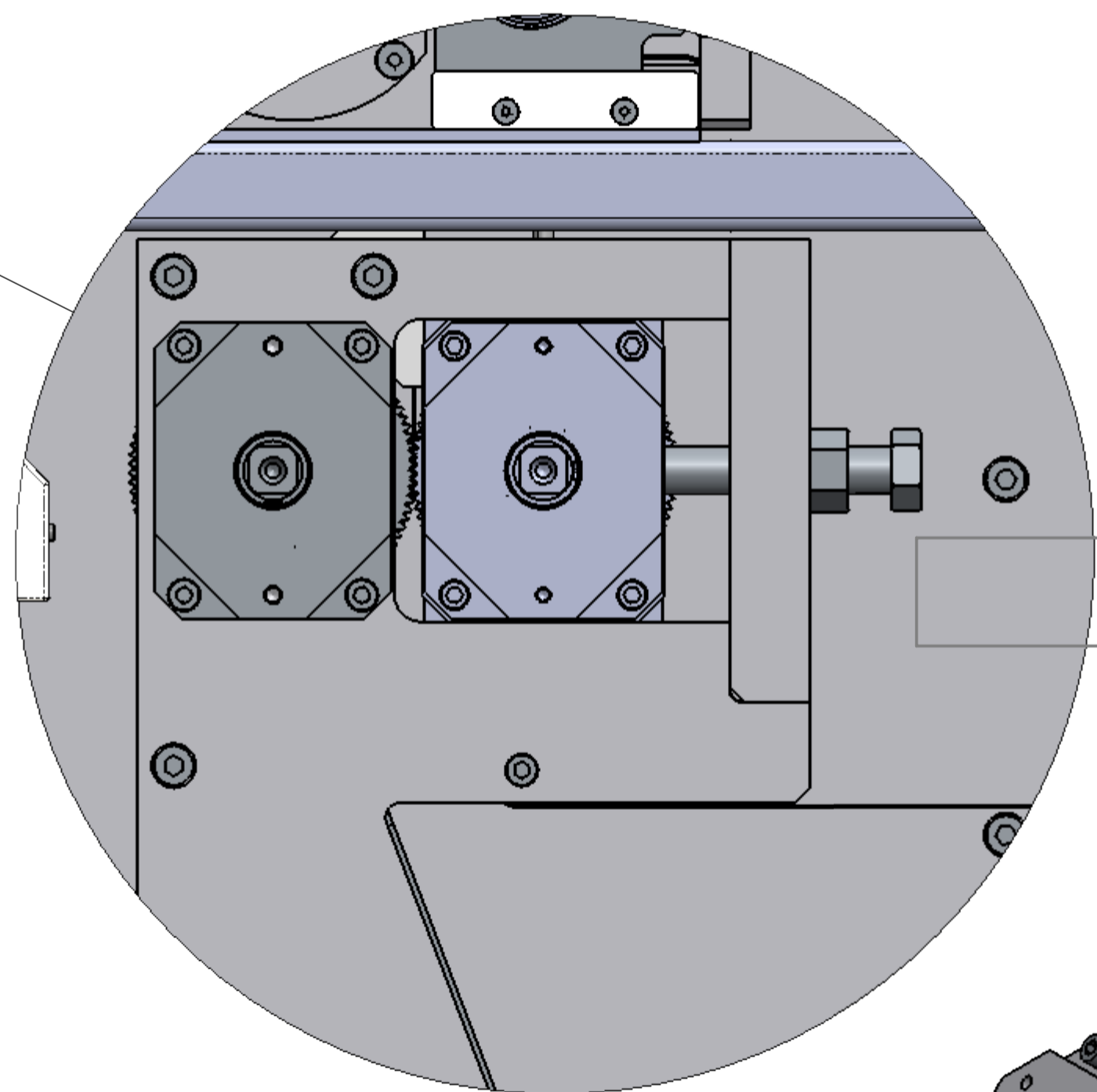

fig.2



NOTE: [ELIMINARE BAVE E SPIGOLI VIVI]

LE TOLLERANZE SI INTENDONO A TRATTAMENTO TERMICO/SUPERFICIALE FINITO		MATERIALE:		MATERIALE:		GENERAL TOLERANCE:	
UNI-EN ISO 22748 mK		MATERIAL SIZE:		WEIGHT: (G)		0.5/45°	
SURFACE FINISH:		THERMAL TREATMENT:		SCALE:		NON-QUOTED CHARACTERS:	
0.4 mm				1:10		UNQUOTED RAYS:	
CREATION DATE:		DESCRIPTION:		SIZE:		0.4 mm	
05/10/2020				A1			
SHEET:				CREATION DATE:			
1/1				05/10/2020			
				SHEET:			
				1/1			
				CODE:			
				PM.101			



THE PRESENT DOCUMENT IS EXCLUSIVE PROPERTY OF V-SHAPES SRL.  
AS LEGAL CONDITION IS FORBIDDEN COPY OR COMMUNICATION  
TO THIRD PARTY WITHOUT AUTHORIZATION BY V-SHAPES SRL.



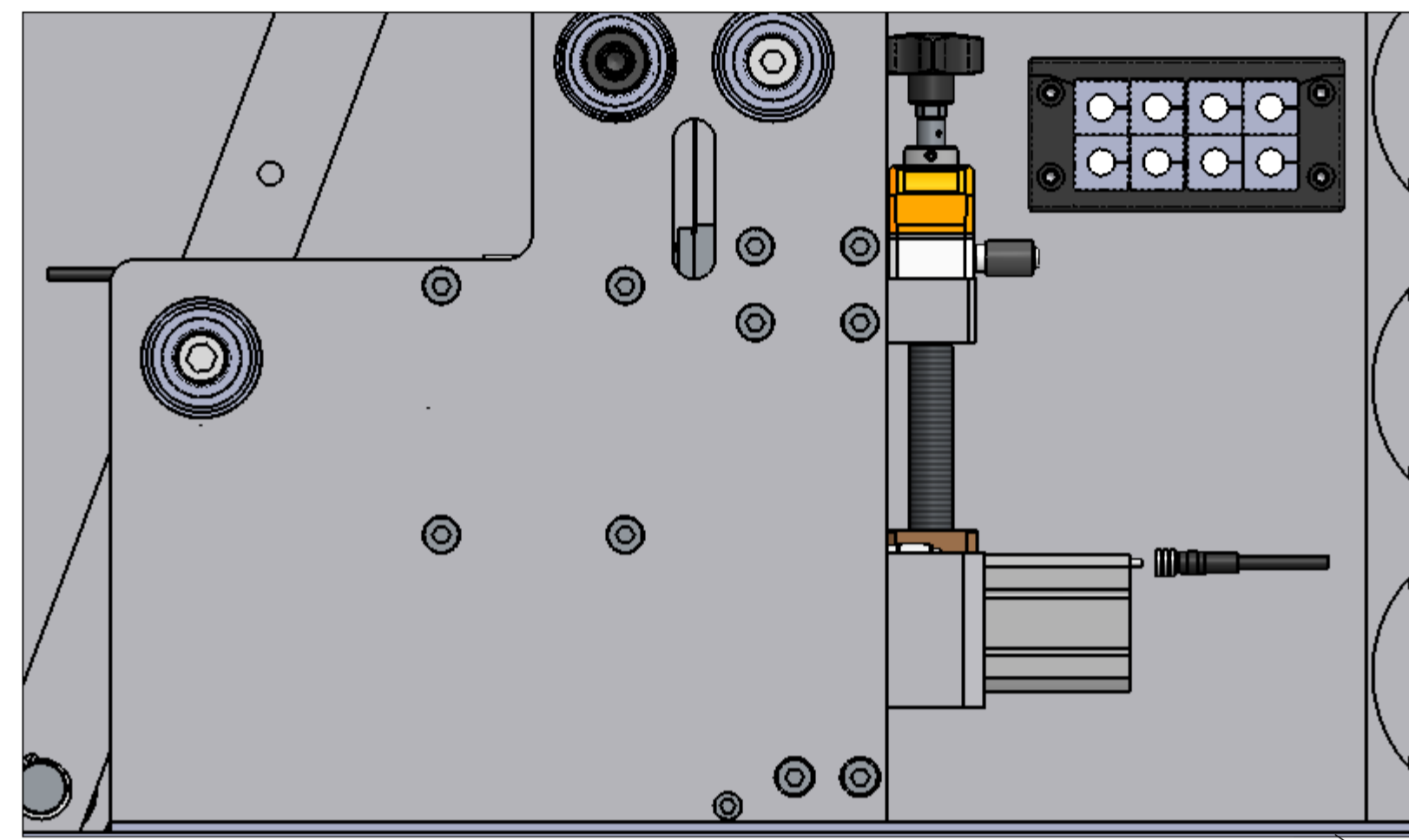

**Internal and external pre-cut area.**  
 the internal pre-cut position is fixed while the external pre-cut is manually adjustable related to sachet size.

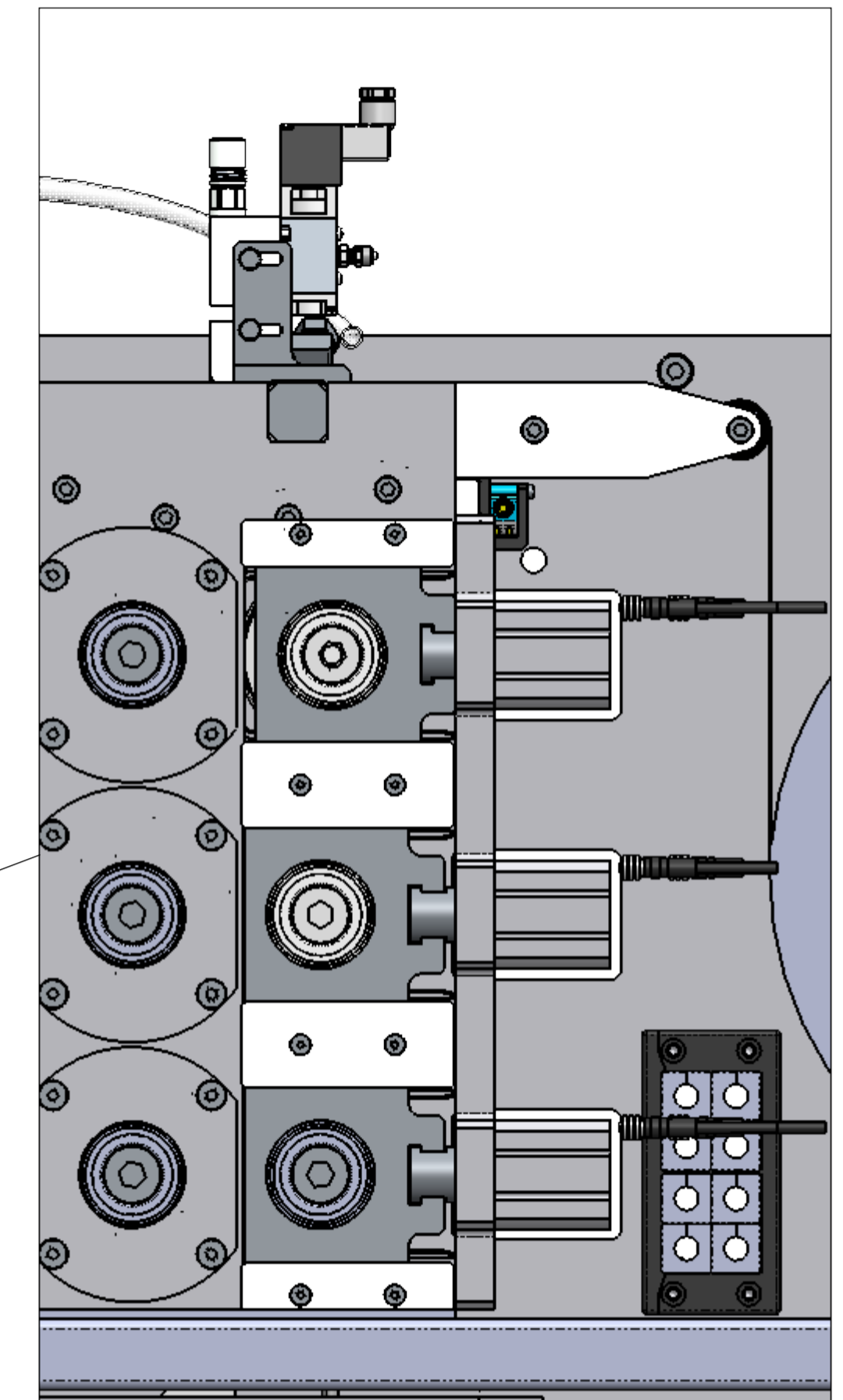

**sealing area:**  
 - welding by hot rollers and crossbar  
 - synchronized control through notch control photocells  
 - during sealing the product is dosed through the nozzle, with the possibility of dosing continuously or in phase  
 the quantity of product to be dosed can be set by means of a pneumatic pump.

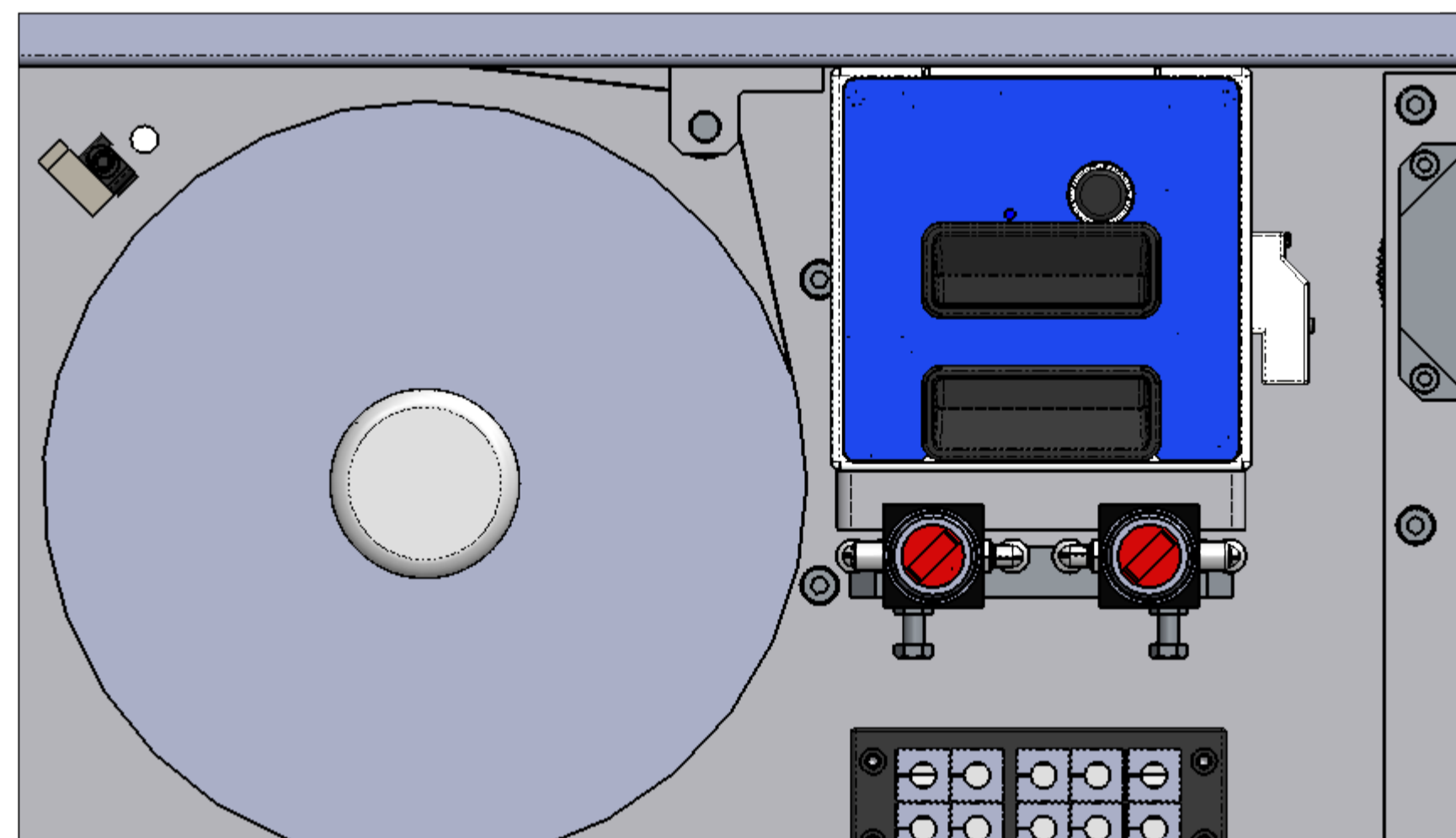

**Print area** for batch and expiry date  
 Printing area 47x32 mm.

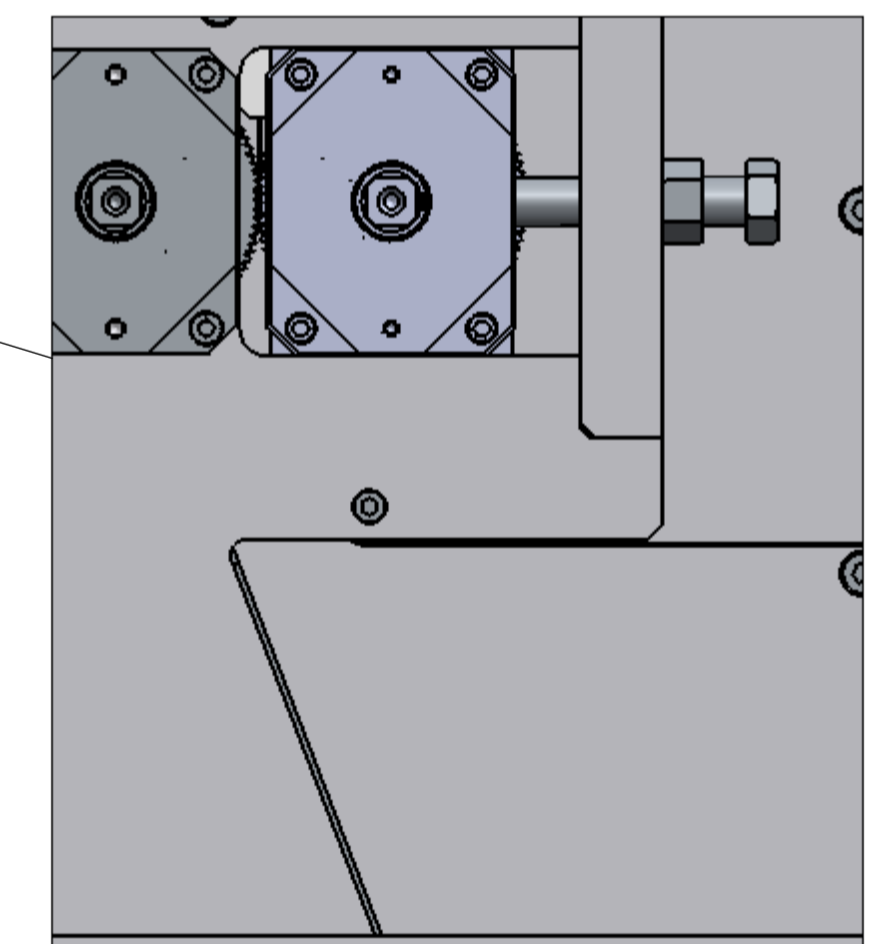
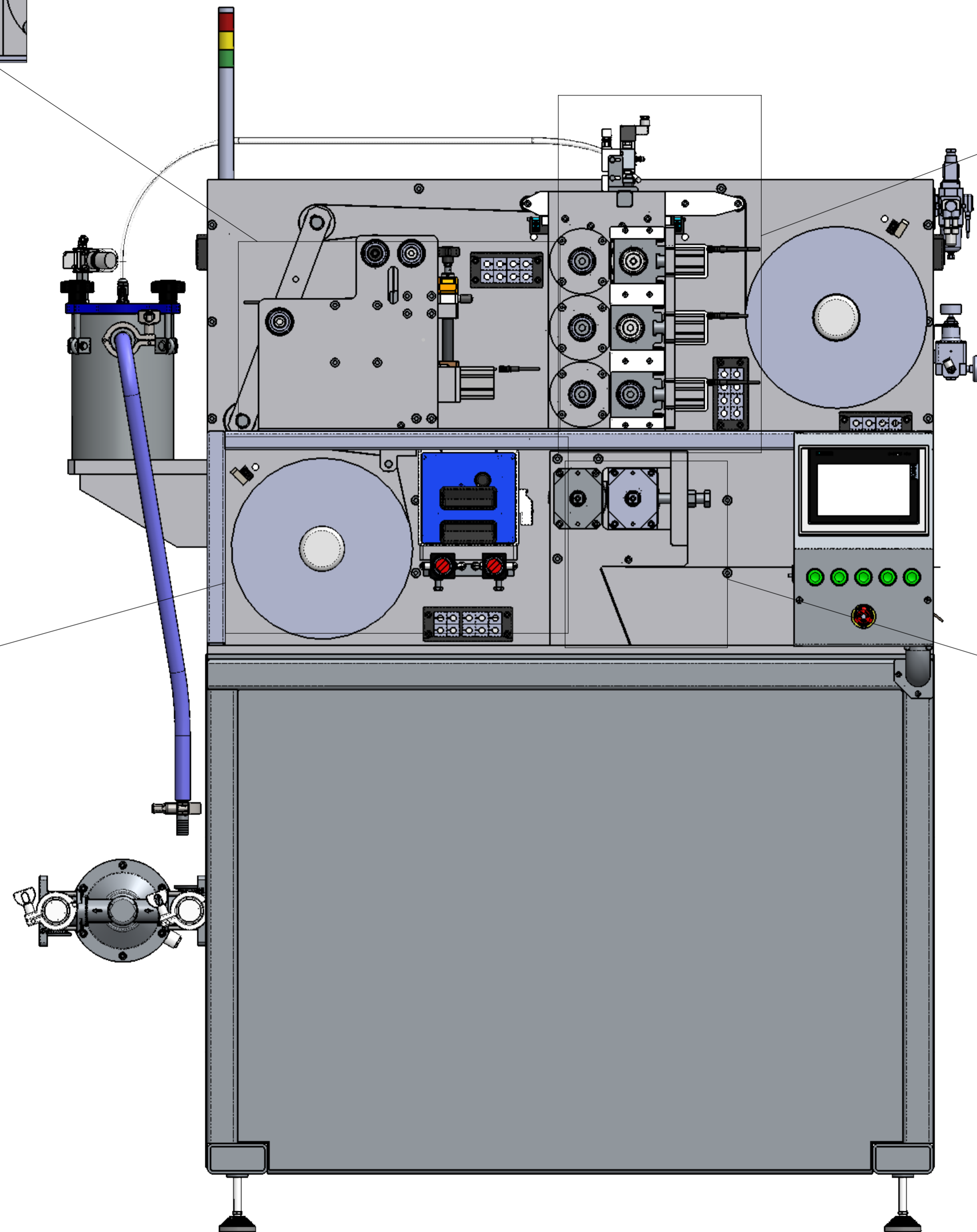

**blanking area**  
 the rotary cutter separates the sachets from the scrap.

NOTE: [ELIMINARE BAVE E SPIGOLI VIVI]

LE TOLLERANZE SI INTENDONO A TRATTAMENTO TERMICO/SUPERFICIALE FINITO

MATERIAL:	UNI-EN ISO 22748 nrx	SCALE:	1:5	GENERAL TOLERANCE:	0.5x45°
MATERIAL SIZE:		WEIGHT:		NON QUOTED CHANGES:	0.4 mm
THERMAL TREATMENT:		SIZE:	A1	UNQUOTED RAYS:	
SURFACE FINISH:		CREATION DATE:	05/10/2020		
DESCRIPTION:		SHEET:	1/1		
THE PRESENT DOCUMENT IS EXCLUSIVE PROPERTY OF V-SHAPES SRL. AS LEGAL CONDITION IS FORBIDDEN COPY OR COMMUNICATION TO THIRD PARTY WITHOUT AUTHORIZATION BY V-SHAPES SRL.			CODE: PM.101		



